

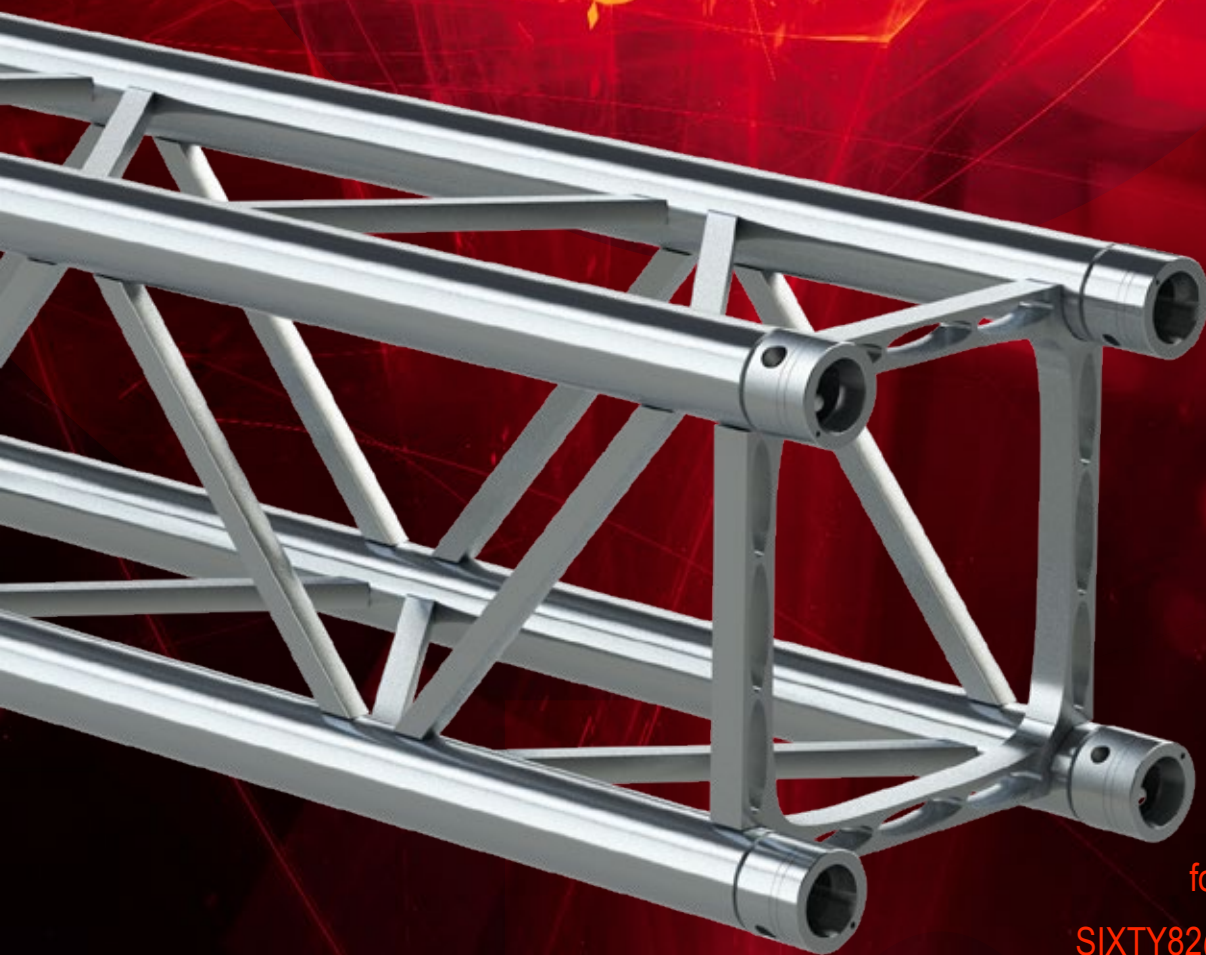

SIXTY82™

# [TPM]

TRUSS SERIES



JSA EUROPE  
official sales partner  
for SIXTY82 products

[SIXTY82@JSA-STAGE.COM](mailto:SIXTY82@JSA-STAGE.COM)

WORLDWIDE PATENT



WE  
MADE  
IT  
FROM  
ONE  
PIECE

# A **REVOLUTIONARY** DESIGN

Introducing the **TPM Truss Series** by **SIXTY82** – the most revolutionary aluminum truss on the market!

Our team at SIXTY82 has spent countless hours researching and developing the perfect aluminum truss, and we are thrilled to finally unveil the TPM Truss Series.

**What sets our truss apart from all others is its strength.**

We've designed it to be up to 25% stronger, ensuring that your structures will be able to withstand even the most demanding conditions.

And our truss is more than just strong – it's also versatile. It can be used for a wide range of applications, from small events and exhibitions to large-scale concerts and festivals. And with its sleek, modern design, it will add a touch of sophistication to any setting.

Don't just take our word for it – try the TPM Truss Series for yourself and experience the difference.

We're confident that once you do, you'll never go back to using any other truss.

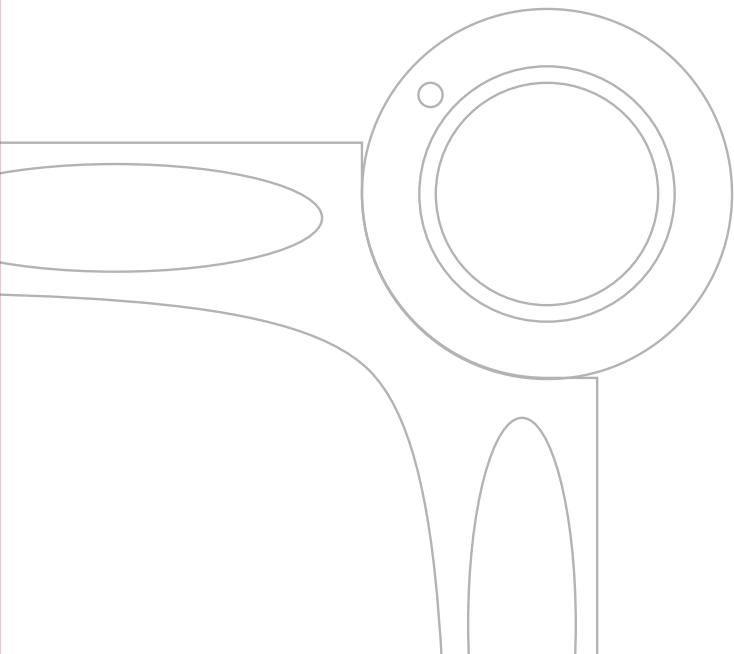

**UP TO 25% STRONGER**  
**BOUNCE AND SMASH PROOF**

**PERFECT FIT**

**100% INTERCHANGEABLE**

**EASY TO PLACE LIGHTING FIXTURES**  
**BECAUSE OF END FRAMES**



# REDESIGNING THE STANDARD

At Sixty82 we have set our self the challenge to re-invent the most used truss type, the M29 Series. The goal was to create an evolution on the standard truss, with beneficial properties over the current M29 Series, while remaining fully interchangeable with the current series.

To achieve these unique properties, we have put countless hours in researching the best solutions. There have been two main innovations to achieve the improved properties.



1

## Re-designed diagonal braces

The improved design of the diagonal braces helps to increase the strength and stability of the truss system. By optimizing the shape and dimensions, the diagonal braces are able to provide better support and withstand higher forces. This helps to improve

the overall strength and performance of the truss, making it more effective at supporting heavy loads.

2

## Extruded end frame

The use of the extruded end frame contributes to the improved strength and performance of the truss system. By using extruded end frames, the TPM Truss is able to withstand more load without deforming or failing.

In addition to the improved strength, the TPM Truss Series is 100% square and has a perfect fit. This is because the extruded end frames are more precise and uniform in shape, which allows them to more easily and securely attach to other truss components. This can help to improve the stability and strength of the overall truss system, and reduce the risk of failure due to poor connections.

Finally, the removal of the end diagonal allows the inside of the truss to be used for storage and makes it very easy to place uprighters in the truss without the end diagonals interfering.



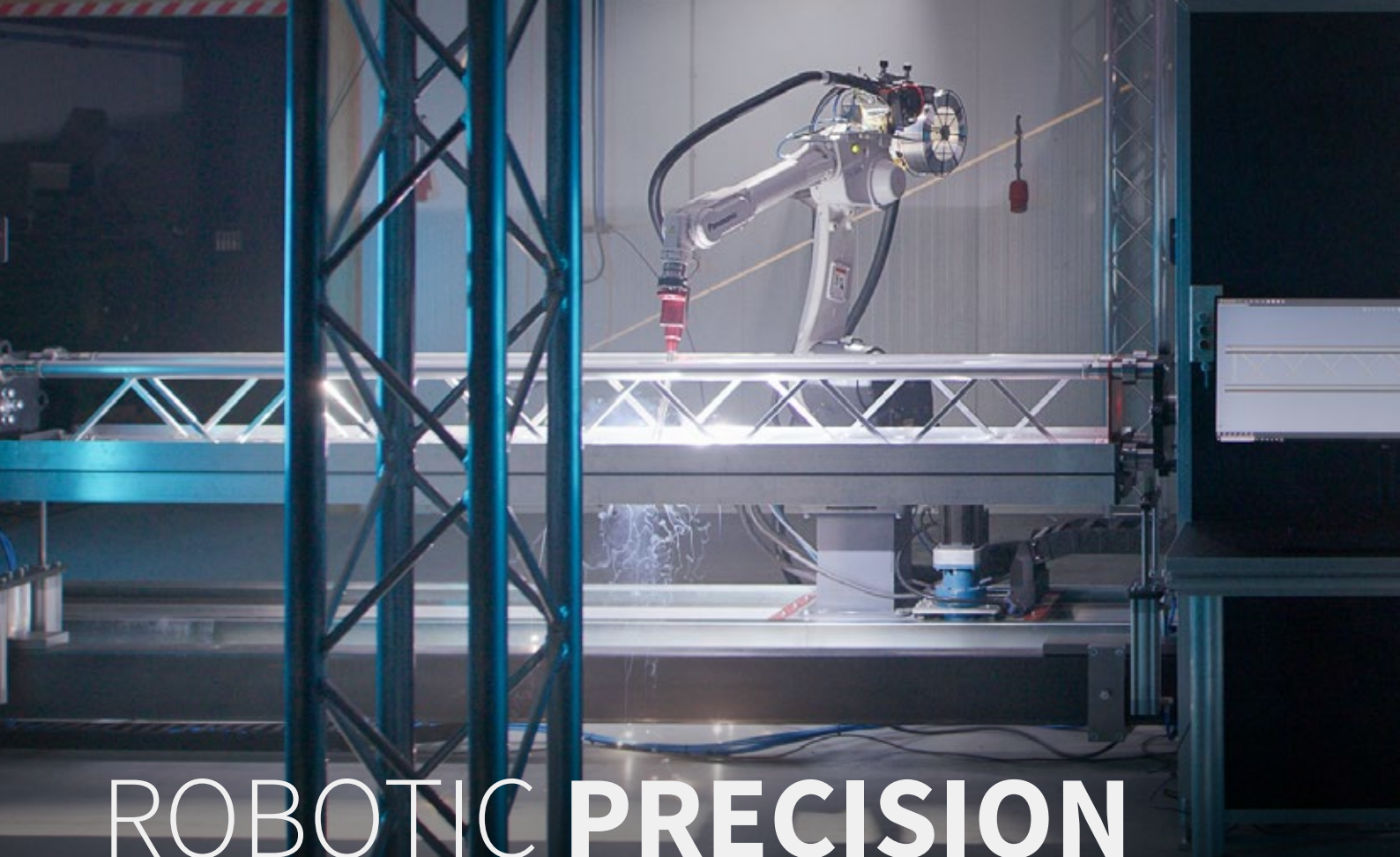

# ROBOTIC PRECISION

## BUT IT'S MORE THAN JUST ROBOTIZING

At our company, we have gone above and beyond to optimize the production of our TPM truss. Instead of simply robotizing the existing design, as many others do, we have taken a holistic approach to improving our production process. We have not only implemented advanced robotics technology, but we have also adapted the design of the truss to fit the robotized production process as perfectly as possible.

This unique approach has allowed us to achieve maximum output and produce a top-quality product. Our commitment to innovation and optimization has helped us offer some of the shortest lead times in the market, making us a reliable and efficient choice for our customers. We have a team of highly skilled professionals in-house who have the knowledge and expertise to design and maintain both the truss and the robot installation, ensuring that we are always producing the best possible product.

## MAXIMUM OUTPUT AND PRODUCE A TOP-QUALITY PRODUCT

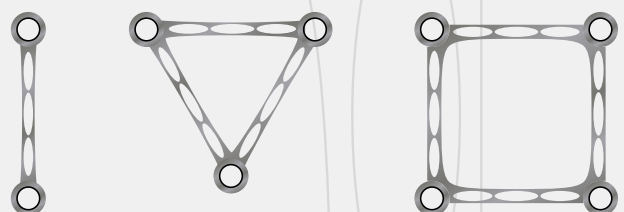

## TPM SPIGOT

An additional key improvement we have made to our TPM truss system is the change in alloy for the truss spigots. By switching to a stronger alloy, we have been able to increase the strength of the truss.

The new spigot is easily distinguishable from the old spigot because of the changed recessed identification line. These new spigots, along with other

optimizations in our production process, have allowed us to offer a product that is up to 25% stronger and more reliable than ever before.



202058 Spigot Model TPM03  
202059 Spigot TPM04 M8 Thread

# INTERCHANGEABLE

With 100% backwards interchangeability, the TPM truss can be seamlessly integrated into any M29 series setup without any problems. In cases where both truss types are used, customers can simply use the loading tables of the M29 truss for safe and reliable operation.

This backwards interchangeability means that our customers can enjoy all the benefits of the new TPM truss without having to worry about compatibility issues. It's the perfect solution for anyone looking to expand their M29 series and take advantage of the latest innovations in truss technology.

## SEAMLESSLY INTEGRATED INTO ANY M29 SERIES







48.3 x 3 mm

# Length Square



TPM29S

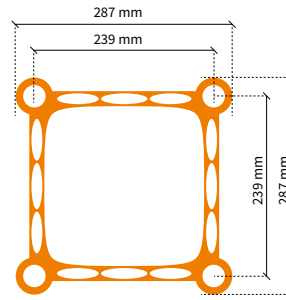
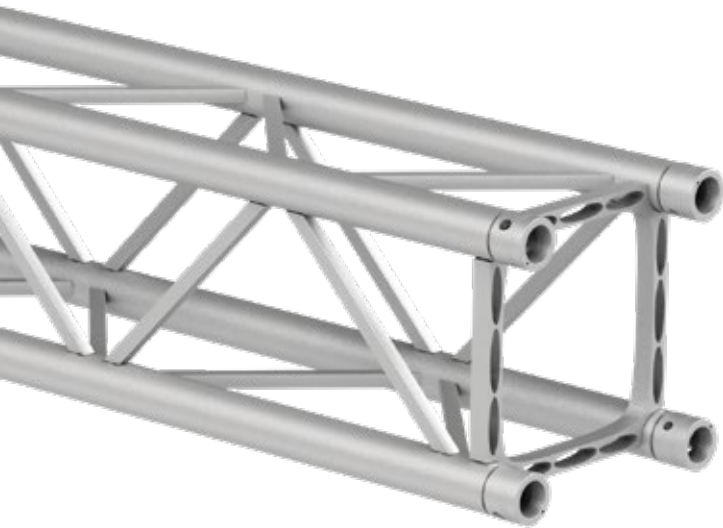

6.4 kg/m



ALU/BLACK



M

((RFID))  
READY

## SQUARE - TPM29S

Code	Length
128501	21 cm
128502	25 cm
128503	29 cm
128504	50 cm
128505	71 cm
128515	75 cm
128506	100 cm
128507	150 cm
128508	200 cm
128509	250 cm
128510	300 cm
128512	400 cm

## LOAD TABLE TPM29S

Span	CPL	Deflection	2 x load	Deflection	3 x load	Deflection	4 x load	Deflection	UDL	Deflection
m	kg	mm	kg	mm	kg	mm	kg	mm	kg/m	mm
2.0	2455.0	3	1227.5	4	818.3	4	613.7	4	1227.5	4
4.0	1399.4	13	972.3	17	779.7	16	610.9	17	610.9	17
6.0	985.9	30	695.2	38	526.7	35	419.7	38	377.0	37
8.0	755.7	53	541.1	68	397.4	63	320.2	68	209.5	66
10.0	607.9	83	440.0	106	316.5	98	256.8	106	132.0	103
12.0	504.2	119	368.0	152	260.6	141	212.7	152	89.9	149
14.0	426.7	162	313.8	207	219.4	192	179.8	207	64.5	202
16.0	366.2	212	271.1	270	187.6	251	154.3	270	48.1	264
20.0	276.5	330	207.5	422	140.8	392	116.6	422	28.7	413

## CANTILEVER LOAD

Span	1 x Load	Deflection	UDL	Deflection
m	kg	mm	kg/m	mm
0.5	1231.8	1	2460.8	0.01
1.0	1230.4	12	1227.5	0.09
1.5	880.0	43	816.4	0.30
2.0	698.0	10.8	610.9	0.71
2.5	577.2	21.9	410.9	1.17
3.0	491.0	38.7	290.3	1.73
3.5	426.3	62.4	219.3	2.43
4.0	375.8	94	171.2	3.27

## MULTIPLE SUPPORTED SPAN

Span	CPL	Deflection	2 x Load	Deflection	UDL	Deflection
m	kg	mm	kg	mm	kg/m	mm
2.0	1783.4	1	914.4	0.1	980.8	0.5
4.0	1703.4	6	903.6	0.5	487.5	3.9
6.0	1184.9	14	653.0	1.2	283.0	11.4
8.0	927.6	25	513.3	2.3	163.7	20.9
10.0	756.1	41	419.5	3.7	107.9	33.6
12.0	632.6	59	351.7	5.3	75.8	49.0
14.0	538.7	79	299.9	7.2	55.6	66.7
16.0	464.4	102	258.9	9.3	42.2	86.2
20.0	352.7	151	197.0	13.8	25.8	144.7

Find complete loading tables on [SIXTY82.nl](http://SIXTY82.nl)

All loading data is based on calculations per EN 17115:2018 and the following assumptions:

- Static loads only.
- Spans supported or suspended at both ends.
- Triangle trusses solely used apex-up, apex-down.
- 2 chords truss to be placed upright or supported from top chord and loaded from bottom chord.
- Truss spans can be assembled from elements of different length.
- Loading data is only applicable when trusses are solely assembled with TPM03/04 (42CrMo4) spigots.

- Interaction of bending moment and shear force considered.
- Self-weight of truss is already considered.
- Assembled truss structures need an individual structural calculation, please contact SIXTY82 or a structural engineer.
- Read the manual before use.
- Higher loading can be allowed depending on the truss configuration.

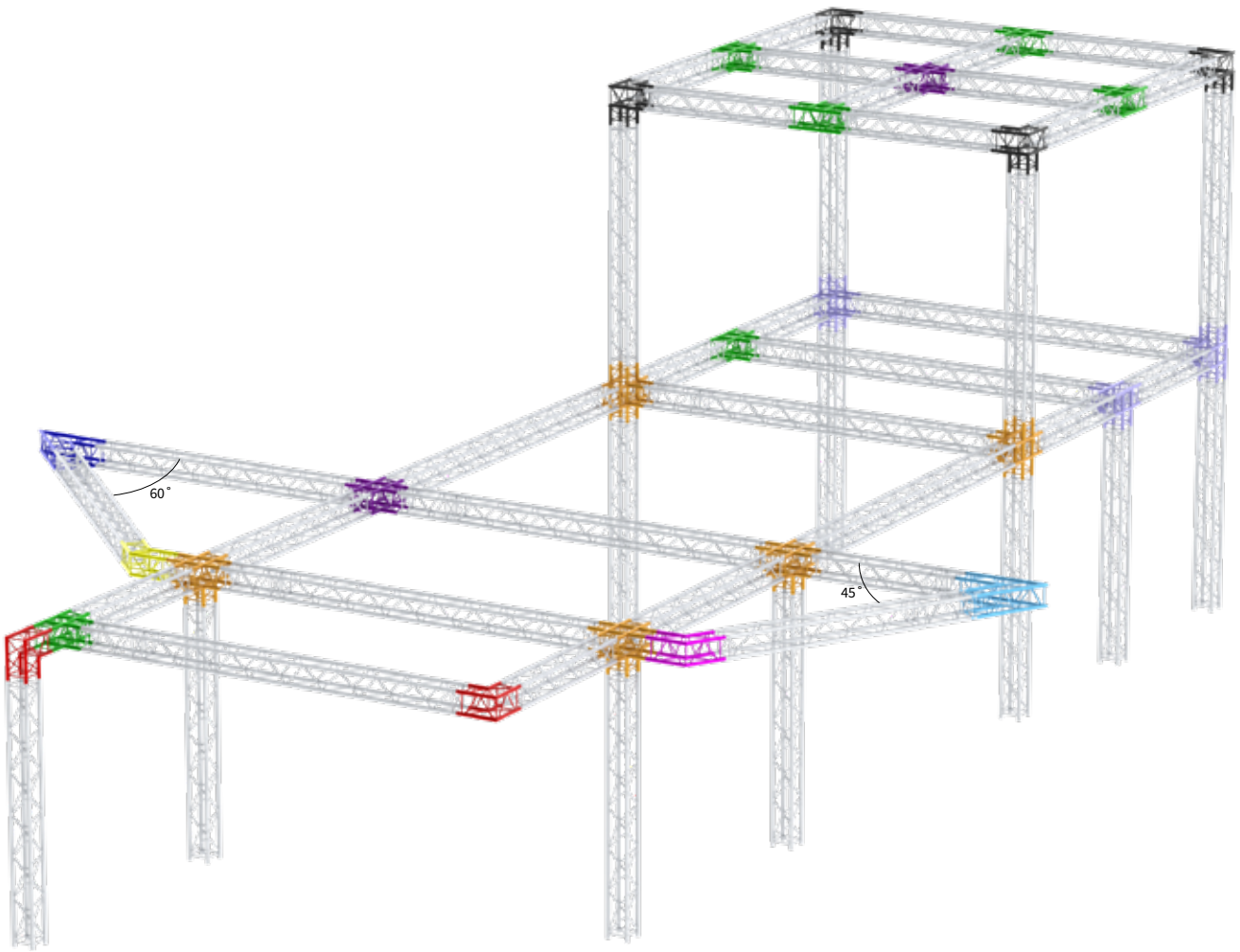

## 2way

**TPM29S-C201** **45°**  
129501 9.7 kg

**TPM29S-C202** **60°**  
129502 10.6 kg

**TPM29S-C203** **90°**  
129503 5.9 kg

**TPM29S-C204** **120°**  
129504 6.6 kg

**TPM29S-C205** **135°**  
129505 7 kg

3way

**TPM29S-C312** 90°  
129506 8 kg

**TPM29S-C317** T JOINT  
129507 8.9 kg

**TPM29S-C350** T JOINT  
129511 kg

4way

**TPM29S-C416** CROSS  
129508 11 kg

**TPM29S-C420** T JOINT  
129509 11 kg

5way

**TPM29S-C524** CROSS  
129510 13.1 kg

BOX

**BOX CORNER** M29S  
199002 8.5 kg

**HALF CONNECTOR** M52S  
202008 0.14 kg

**RECEIVER** M51  
202009 0.28 kg

Circle



TPM29S CIRCLE PART

- 6.4 kg/m
- M
- ALU/BLACK
- ((RFID))  
READY

Code	Ø Diameter	Angle	Parts/Circle
130501	2 m	90	4
130502	3 m	90	4
130503	4 m	90	4
130504	5 m	90	4
130505	6 m	45	8
130506	8 m	45	8
130507	10 m	30	12
130508	10 m	45	8



SIXTY82™

**[TPM]**  
TRUSS SERIES

Sixty82 BV

Ampèrelaan 9 | 9207 AM Drachten | The Netherlands

+31 88 13 422 00

info@sixty82.nl

www.sixty82.nl

WE ARE THE INNOVATORS



**JSA EUROPE -  
official sales partner  
for SIXTY82 products  
SIXTY82@JSA-STAGE.COM**

MADE IN HOLLAND

WORLDWIDE PATENT